

Item No. _____

Quantity _____

Model No. 8300, 8300-220, 8301 Counter Top Hot Dog Steamer



8300

Turn your countertop into money-making real estate with Nemco's new Hot Dog Steamer! The Nemco Steamer will warm it, store it and sell it with its great merchandising appeal! Steam Hot Dogs, then serve them on fresh and tasty Buns!

The steamer is equipped with a large compartment that will steam up to 150, 10-count hot dogs and 30 buns. It will accommodate 2 each 6" hot dogs from front to rear of the unit. The high profile of the unit, unique merchandising graphics and see-through tempered glass back panel allows you to put this on a counter anywhere to get the most out of your space!

The front, top, sides and inside of the unit are constructed of brushed rust-resistant stainless steel. The steamer is equipped with an easy-to-activate drain for easy cleaning, a lighted power switch and a Low Water indicator light (not included on Model No. 8301). The tempered glass sliding doors allow easy access to both hot dogs & buns. Easy-to-use controls include an adjustable thermostat. Now you can serve your customers fresh and tasty hot dogs, a fan favorite, in just 1 1/2 square feet of counterspace!

Standard Features:

- Brushed 304 stainless steel cabinet and base
- Tempered glass back panel for merchandising appeal
- Tempered glass sliding doors
- Attractive merchandising graphics
- Low water indicator light (not included on Model No. 8301)
- Drain, allowing for easy cleaning
- Lighted power switch
- Adjustable thermostat
- 150 10-count hot dog capacity
- 30 bun capacity
- 7 1/2 quart water reservoir
- Six foot cord and NEMA 5-15p plug
- One year parts and labor warranty



NEMCO Food Equipment, LTD.
301 Meuse Argonne
P.O. Box 305
Hicksville, OH 43526
(800) 782-6761
Phone (419) 542-7751
FAX (419) 542-6690
www.nemcofoodequip.com

Model No. 8300/8301

AIA File No.

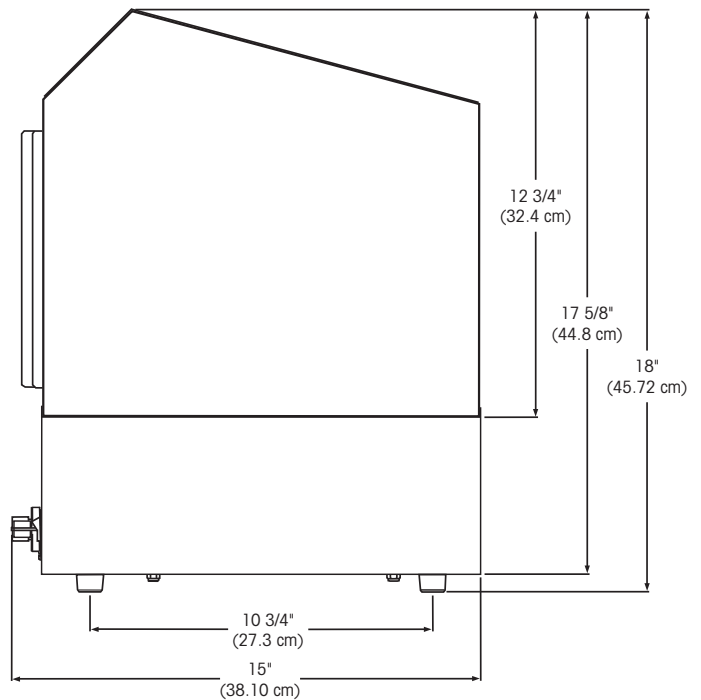
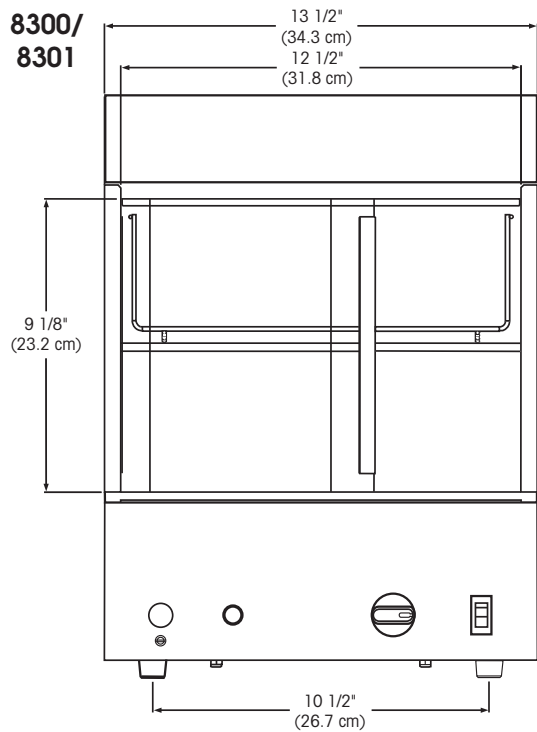

Model No.	Capacity (preheat time)	Width Inches (cm)	Depth Inches (cm)	Height Inches (cm)	Voltage	Wattage	Amperage	NEMA Plug Configuration	Actual Weight (Kg)	Shipping Weight (Kg)
8300	150 (20 min)	13.5 (34.3)	15 (38.1)	18 (45.7)	120	800	6.7	5-15p	29 (13.2)	35 (15.9)
8300-220	150 (20 min)	13.5 (34.3)	15 (38.1)	18 (45.7)	220	800	3.6	6-15p	29 (13.2)	35 (15.9)
8301	150 (20 min)	13.5 (34.3)	15 (38.1)	18 (45.7)	120	800	6.7	5-15p	29 (13.2)	35 (15.9)

Typical Specifications

Electric countertop hot dog steamers shall have a stainless steel body and interior and be equipped with a thermostatic control and metal sheath heating element. Model No. 8300 shall be equipped with a low water indicator light (not included on the Model No. 8301). The unit shall have tempered sliding glass doors and merchandising glass at rear of unit. The unit shall have a maximum heat setting of 200°F. 120V unit shall have a 6' cord and NEMA 5-15p plug; 220V unit shall have a 6' cord and NEMA 6-15p plug. Electric hot dog steamers carry the approval of UL Testing Laboratories and shall be listed with the National Sanitation Foundation.



NEMCO Food Equipment, LTD.
301 Meuse Argonne, P.O. Box 305
Hicksville, OH 43526
(800) 782-6761
Phone (419) 542-7751
FAX (419) 542-6690

Suburban Brewery Equip.com

5/06 Printed in U.S.A.