

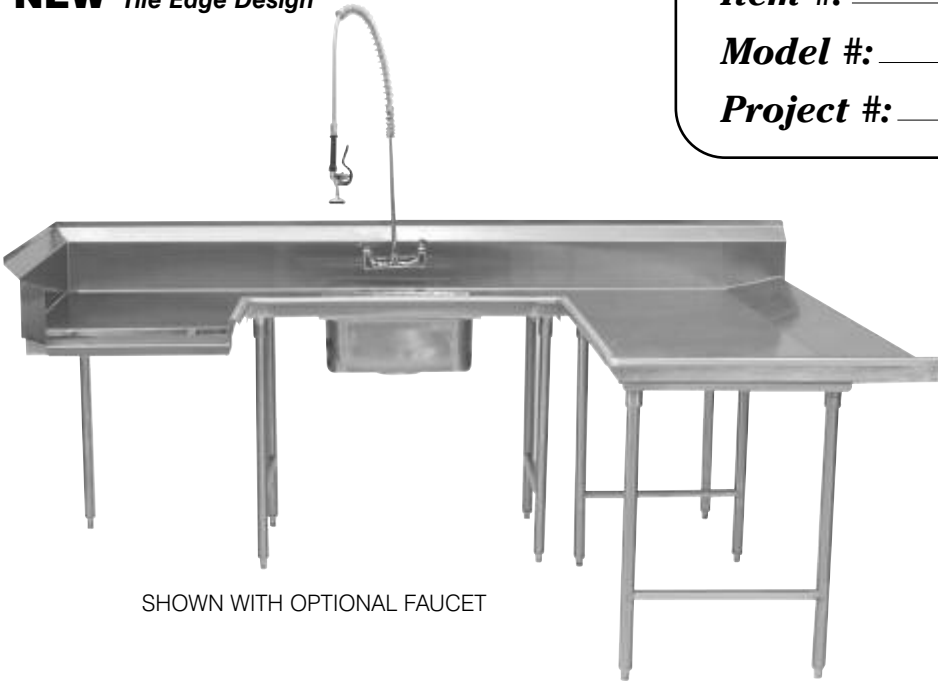

STAINLESS STEEL
U-SHAPED SOIL DISHTABLE **NSF**

NEW Tile Edge Design

Item #: _____ **Qty #:** _____
Model #: _____
Project #: _____



SHOWN WITH OPTIONAL FAUCET



**10-1/2" EXTRA LARGE
 Bold Looking Backsplash
 with 2" return and tile edge**

FEATURES:

- Tile edge for ease of installation.
- Includes 8" deep Prerinse Sink Basket and Bar Slide and Dishlanding.
- Additional length on any leg of dishtables, use **DTA-56**.
- Additional custom lengths available on all sides.
- Dishlanding may be replaced with backsplash or rolled edge at no additional charge.
- Dishtable lengths exceeding 90" requires a welded field joint (welded by others). Use **K-57**.

CONSTRUCTION:

- All TIG welded.
- 14 Gauge Stainless Steel.
- Stainless Steel Legs and Cross Bracing.
- Stainless Steel Bullet Feet.
- Gussets welded to Stainless Steel Channels.
- Welded areas blended to match adjacent surfaces and to a satin finish.

MECHANICAL:

- Faucet holes in splash punched 8" on center. Faucet not included.
- Includes 1-1/2" I.P.S. Basket Type Waste Drain.

Model #	Inches	mm	Cu	Wt.
DTS-U30-72LorR	72"	1828	108	450 lbs.
DTS-U30-84LorR	84"	2134	125	470 lbs.
DTS-U30-96LorR*	96"	2438	143	490 lbs.
DTS-U30-108LorR*	108"	2743	160	525 lbs.
DTS-U30-120LorR*	120"	3048	177	550 lbs.
DTS-U30-132LorR*	132"	3353	194	575 lbs.
DTS-U30-144LorR*	144"	3658	211	600 lbs.

*Includes Field Joint to be welded in field by others.

<p>ADVANCE TABCO SMART FABRICATION™ www.advancetabco.com</p>	<p>Customer Service Available To Assist You 1-800-645-3166 8:30 am - 8:00 pm E.S.T. Email Orders To: customer@advancetabco.com. For Smart Fabrication™ Quotes, Email To: smartfab@advancetabco.com or Fax To: 631-586-2933</p>			
	<p>NEW YORK Fax: (631) 242-6900</p>	<p>GEORGIA Fax: (770) 775-5625</p>	<p>TEXAS Fax: (972) 932-4795</p>	<p>NEVADA Fax: (775) 972-1578</p>

DIMENSIONS and SPECIFICATIONS

ALL DIMENSIONS ARE TYPICAL

TOL ± .500"

SEE DISH MACHINE COMPATIBILITY CHART TO ENSURE PROPER FIT
 Dish Machine Compatibility Chart can be found on our website at www.advancetabco.com under "Product Support"

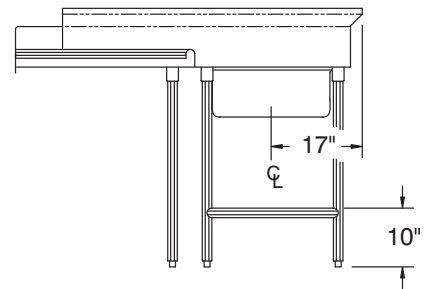
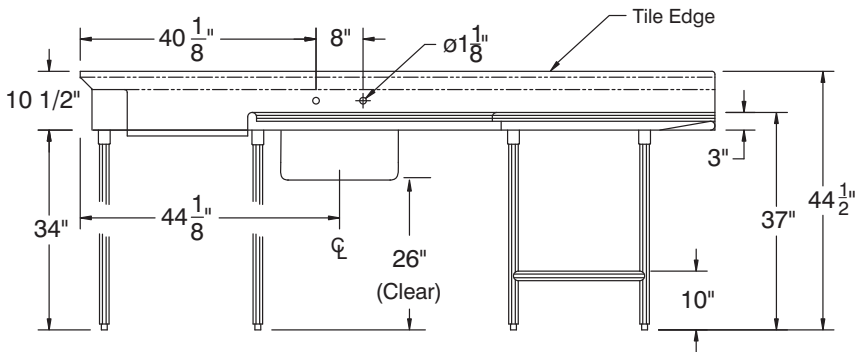
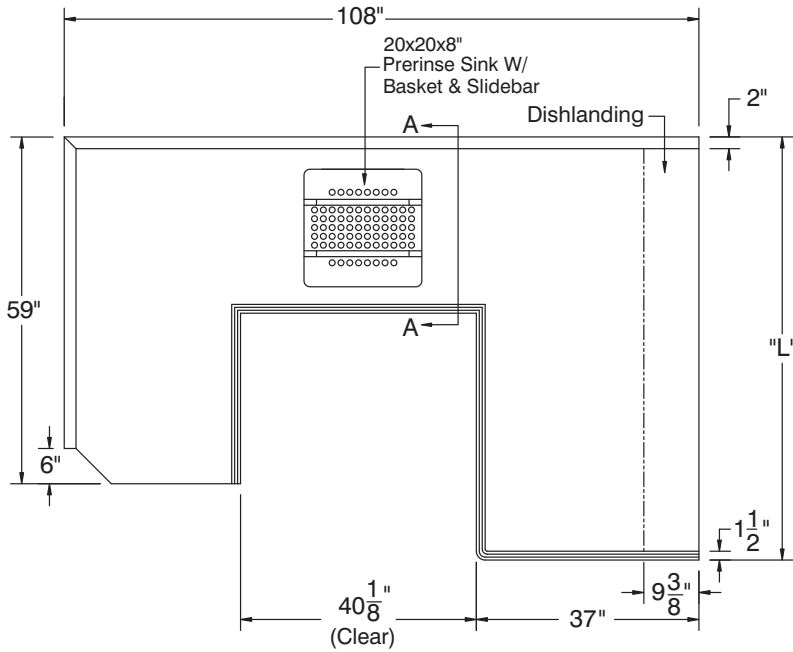

SECTION A-A

