

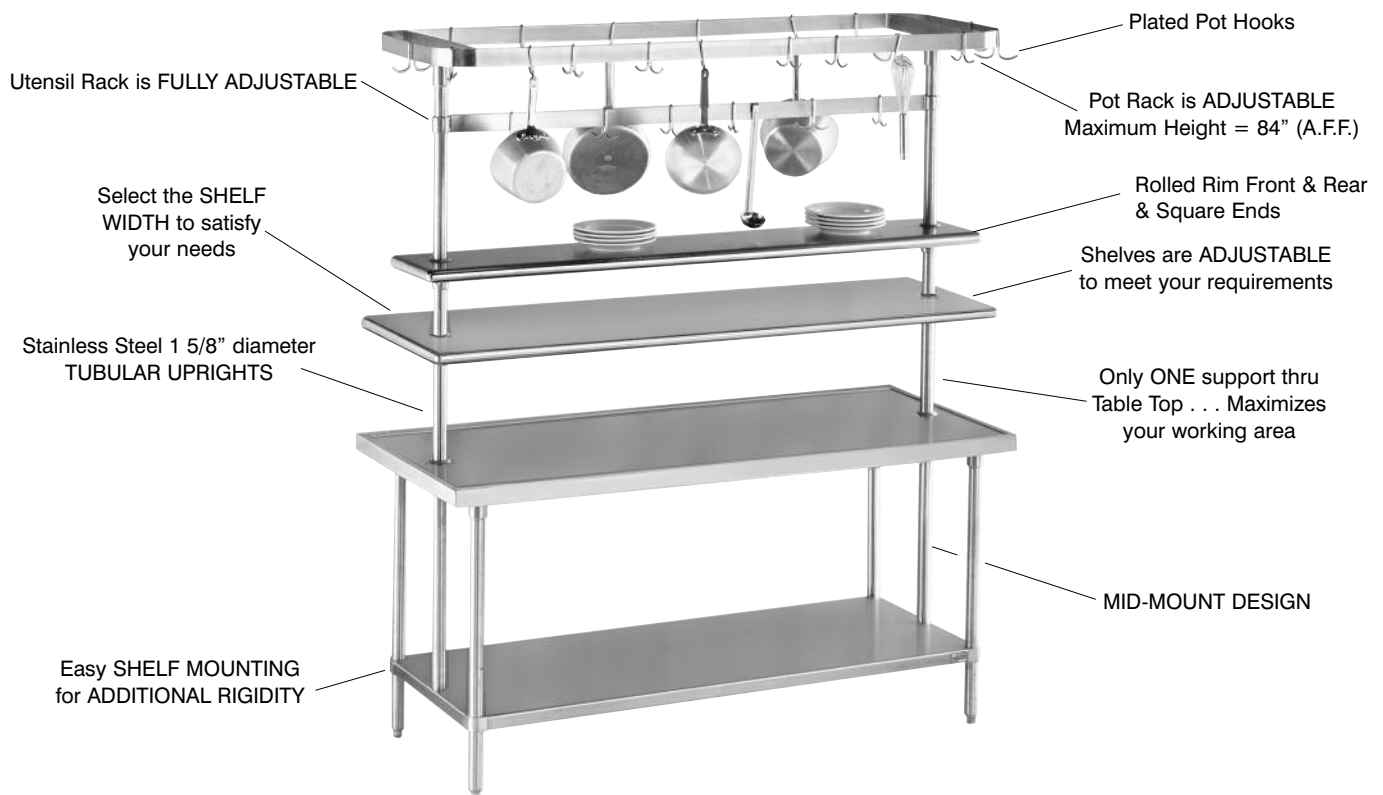

**MIX & MATCH
ADJUSTABLE COMPONENTS**
Stainless Steel
SHELVING - POT RACK - UTENSIL RACK

Convert Your Table into a Effective Work Station!
Maximize Your Work Area!

Our TABLE with POT RACK, SHELVING & UTENSIL RACK



YES!!! it's ADJUSTABLE

Mix & Match your choice. We offer 3 basic components: SHELF - POT RACK - UTENSIL RACK.

The Adjustable Solution components are adjustable. You set the height to meet your demanding requirements.

Focus on Function available in 4 shelf widths, 2 pot rack styles, 10 lengths, and 1 utensil rack series.



Customer Service Available To Assist You 1-800-645-3166 8:30 am - 8:00 pm E.S.T.
Email Orders To: customer@advancetabco.com. For Smart Fabrication™ Quotes, Email To: smartfab@advancetabco.com or Fax To: 631-586-2933

NEW YORK
Fax: (631) 242-6900

GEORGIA
Fax: (770) 775-5625

TEXAS
Fax: (972) 932-4795

NEVADA
Fax: (775) 972-1578

DESIGNED & CONSTRUCTED so as to be a Self-Contained Unit

Possible **ADJUSTABLE** Solutions for ALL Standard ADVANCE TABCO Tables

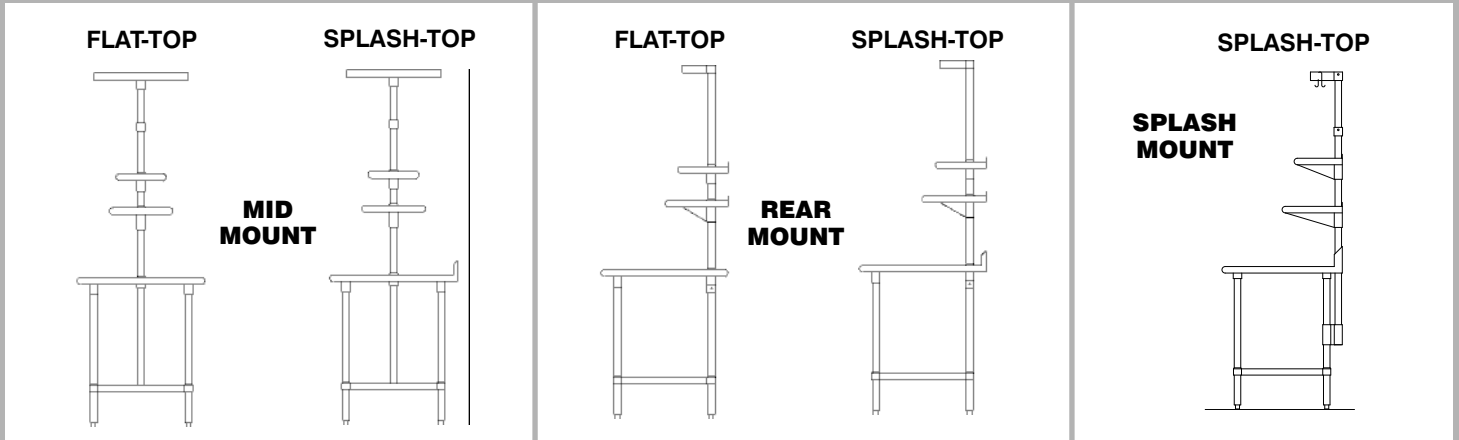

Also Adaptable to ALL ADVANCE TABCO Open - Base (less undershelf) Units.

SHELF SPECIFICATIONS:

REAR MOUNT & SPLASH MOUNT DESIGN:
Shelves feature a 1 1/2" splash on rear edge. Front edge has a rolled rim and square sides.

MID MOUNT DESIGN:
Shelves feature a rolled rim on front and rear & square sides.

TUBULAR UPRIGHT DIMENSIONS	
furnished with units requiring pot racks, shelves and utensil rack. (Dim. A.F.F.)	84"
furnished with units requiring ONLY shelving. (Dim. A.F.F.)	60"
furnished with units requiring field retrofit to include pot rack. Model TA-225 (ext. assembly)	24"

A.F.F. = Above Finished Floor.

SINGLE POST DESIGN MAXIMIZES YOUR WORK AREA!

TABLE with OVERHEAD SHELVES

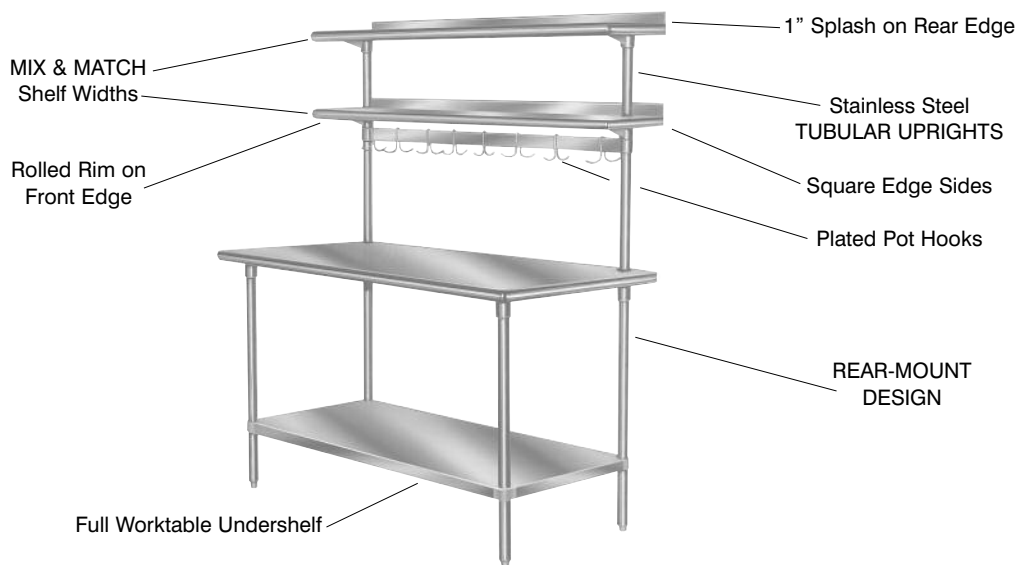

MODELS - DIMENSIONS - WEIGHTS

Choose a *SHELF* or *SHELVES - POT RACK - UTENSIL RACK* and one of the following *Mounting Provisions*:

TA-229 = REAR MOUNT

TA-228 = MID MOUNT

TA-227 = SPLASH MOUNT

NOTE: Adjustable utensil rack is always supplied when ordering POT RACK.

TA-225 = EXTENSION TUBE ASSEMBLY

FACTORY INSTALLATION REQUIRED OF MOUNTING ASSEMBLY.

SHELVING MODELS

WIDTH	Length	MID MT.	REAR MT.	SPLASH MT.	Est. Wt.
10"	36"	PT-10-36	PT-10R-36	PT-10S-36	12 lbs.
	48"	PT-10-48	PT-10R-48	PT-10S-48	14 lbs.
	60"	PT-10-60	PT-10R-60	PT-10S-60	17 lbs.
	72"	PT-10-72	PT-10R-72	PT-10S-72	19 lbs.
	84"	PT-10-84	PT-10R-84	PT-10S-84	22 lbs.
	96"	PT-10-96	PT-10R-96	PT-10S-96	26 lbs.
	108"	PT-10-108	PT-10R-108	PT-10S-108	28 lbs.
	120"	PT-10-120	PT-10R-120	PT-10S-120	31 lbs.
12"	132"	PT-10-132	PT-10R-132	PT-10S-132	35 lbs.
	144"	PT-10-144	PT-10R-144	PT-10S-144	38 lbs.
	36"	PT-12-36	PT-12R-36	PT-12S-36	13 lbs.
	48"	PT-12-48	PT-12R-48	PT-12S-48	15 lbs.
	60"	PT-12-60	PT-12R-60	PT-12S-60	18 lbs.
	72"	PT-12-72	PT-12R-72	PT-12S-72	20 lbs.
	84"	PT-12-84	PT-12R-84	PT-12S-84	23 lbs.
	96"	PT-12-96	PT-12R-96	PT-12S-96	27 lbs.
15"	108"	PT-12-108	PT-12R-108	PT-12S-108	29 lbs.
	120"	PT-12-120	PT-12R-120	PT-12S-120	32 lbs.
	132"	PT-12-132	PT-12R-132	PT-12S-132	36 lbs.
	144"	PT-12-144	PT-12R-144	PT-12S-144	39 lbs.
	36"	PT-15-36	PT-15R-36	PT-15S-36	15 lbs.
	48"	PT-15-48	PT-15R-48	PT-15S-48	17 lbs.
	60"	PT-15-60	PT-15R-60	PT-15S-60	20 lbs.
	72"	PT-15-72	PT-15R-72	PT-15S-72	22 lbs.
18"	84"	PT-15-84	PT-15R-84	PT-15S-84	25 lbs.
	96"	PT-15-96	PT-15R-96	PT-15S-96	29 lbs.
	108"	PT-15-108	PT-15R-108	PT-15S-108	31 lbs.
	120"	PT-15-120	PT-15R-120	PT-15S-120	34 lbs.
	132"	PT-15-132	PT-15R-132	PT-15S-132	38 lbs.
	144"	PT-15-144	PT-15R-144	PT-15S-144	41 lbs.
	36"	PT-18-36	PT-18R-36	PT-18S-36	17 lbs.
	48"	PT-18-48	PT-18R-48	PT-18S-48	19 lbs.
60"	PT-18-60	PT-18R-60	PT-18S-60	22 lbs.	
72"	PT-18-72	PT-18R-72	PT-18S-72	24 lbs.	
84"	PT-18-84	PT-18R-84	PT-18S-84	27 lbs.	
96"	PT-18-96	PT-18R-96	PT-18S-96	31 lbs.	
108"	PT-18-108	PT-18R-108	PT-18S-108	33 lbs.	
120"	PT-18-120	PT-18R-120	PT-18S-120	36 lbs.	
132"	PT-18-132	PT-18R-132	PT-18S-132	40 lbs.	
144"	PT-18-144	PT-18R-144	PT-18S-144	43 lbs.	

POT RACKS

(Includes Adjustable Utensil Rack & Pot Hooks)

SIZE	MID Mount	REAR Mount	SPLASH Mount	# of Hooks	Est. Wt.
36"	SCT-36	SWT-36	SWTB-36	12	30 lbs.
48"	SCT-48	SWT-48	SWTB-48	12	34 lbs.
60"	SCT-60	SWT-60	SWTB-60	18	37 lbs.
72"	SCT-72	SWT-72	SWTB-72	18	46 lbs.
84"	SCT-84	SWT-84	SWTB-84	18	50 lbs.
96"	SCT-96	SWT-96	SWTB-96	18	55 lbs.
108"	SCT-108	SWT-108	SWTB-108	18	60 lbs.
120"	SCT-120	SWT-120	SWTB-120	18	65 lbs.
132"	SCT-132	SWT-132	SWTB-132	18	68 lbs.
144"	SCT-144	SWT-144	SWTB-144	18	72 lbs.

NOTE: "SWT" and "AUR" models align with rear table legs and are 6" less than the nominal foot length.

UTENSIL RACKS

(Includes Pot Hooks)

SIZE	MODEL #	# of Hooks	Est. Wt.
36"	AUR-36	6	10 lbs.
48"	AUR-48	6	12 lbs.
60"	AUR-60	9	14 lbs.
72"	AUR-72	9	16 lbs.
84"	AUR-84	9	18 lbs.
96"	AUR-96	9	20 lbs.
108"	AUR-108	9	22 lbs.
120"	AUR-120	9	24 lbs.
132"	AUR-132	9	26 lbs.
144"	AUR-144	9	28 lbs.



Customer Service Available To Assist You **1-800-645-3166** 8:30 am - 8:00 pm E.S.T.

Email Orders To: customer@advancetabco.com. For Smart Fabrication™ Quotes, Email To: smartfab@advancetabco.com or Fax To: 631-586-2933

NEW YORK
Fax: (631) 242-6900

GEORGIA
Fax: (770) 775-5625

TEXAS
Fax: (972) 932-4795

NEVADA
Fax: (775) 972-1578

SPECIFICATIONS

TABLE with SHELVES, POT RACK & UTENSIL RACK

MID-MOUNT INSTALLATION

REAR-MOUNT INSTALLATION

Suggested Heights an Typical Installations

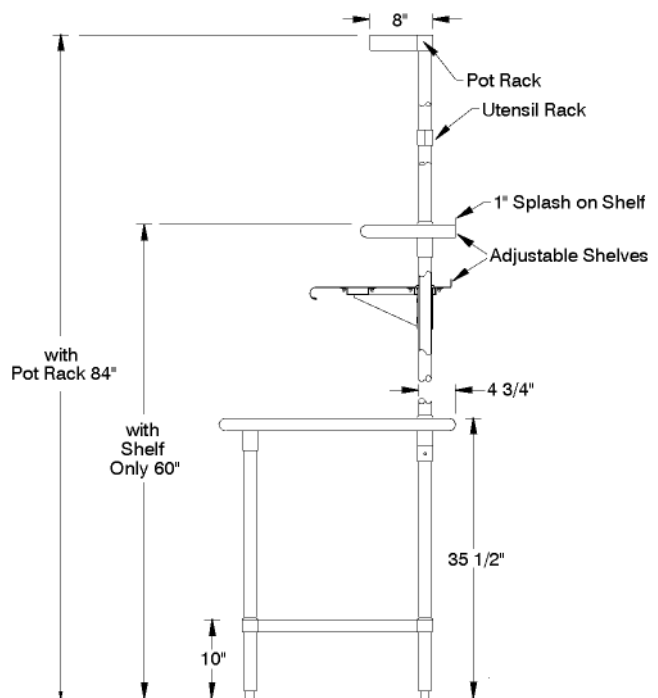
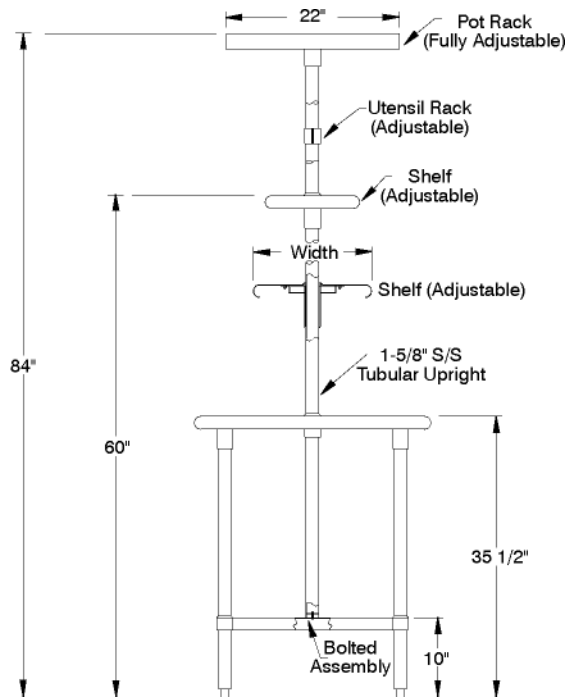

ALL DIMENSIONS ARE TYPICAL

A.F.F. = Above Finished Floor

Table Mounted Shelf Installation

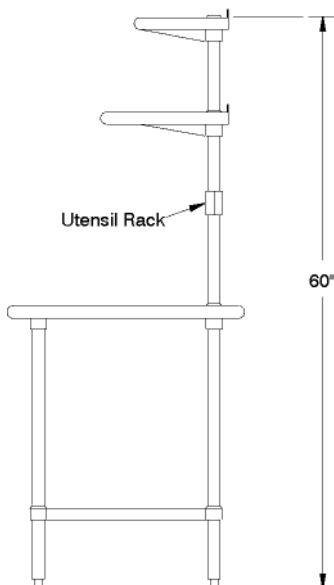

DESIGN:

SHELVES, POT & UTENSIL RACKS are adjustable along a single tubular upright at each end of the table.

Gusset type SET SCREW LOCKING MECHANISMS are employed to secure in place.

HAT SECTIONS and ANGLE BRACKETS, where required, are supplied to insure a rigid and level working surface.

MATERIAL:

SHELVES, POT & UTENSIL RACKS, HAT SECTION and GUSSETS are stainless steel.

SHELF DESIGN:

MID-MOUNTED SHELVING UNITS are furnished with a roll rim edge on front and rear sides.

REAR & SPLASH MOUNTED SHELVING UNITS are furnished with a roll rim edge in front. Ends are square edged formed downward and rear edge is turned up to form a rear splash.

CONSTRUCTION:

TIG welded with exposed areas polished to match adjacent surfaces.

Units originally supplied with OVERHEAD SHELVING can be adapted on the field to receive a POT RACK.

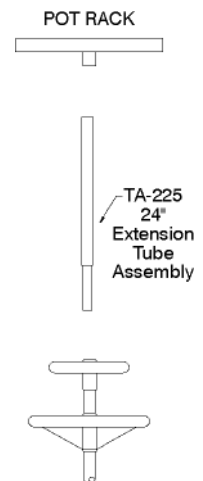

ADVANCE TABCO is constantly engaged in a program of improving our products. Therefore, we reserve the right to change specifications without prior notice.